



EUROLLS

Rolls and rolling cassettes for the wire industry

EUROLLS

Contents

2	Eurolls: Wire Industry
4	Application Sectors
6	Innovation: Blue Sky Box
12	Rolling Cassettes
12	Industrial Wire
16	Construction Wire
20	High Carbon
22	Special Applications
24	Rolls
26	Accessories
28	Services
30	Company

WIRE INDUSTRY

EUROLLS

With over 30 years of experience, Eurolls is recognized as a benchmark of Italian excellence in wire rolling, delivering consistently high production quality.

This commitment to quality has been a cornerstone of the company, earning the trust of customers worldwide. Our solutions for the wire industry are designed to provide customers with a single partner for the entire production process. Through our Industrial Division, Eurolls supplies every type of machine for wire production, complemented by in-house-manufactured ancillary products such as rolls and rolling cassettes.

Completing our wide product range is a team of specialists who support customers from the design phase to commissioning, offering professional and continuous assistance.

Innovation is at the heart of Eurolls. As a trusted partner of leading companies, we uphold the highest machinery quality standards while maintaining our signature Italian excellence.

Eurolls, innovation that keeps you rolling!



INDUSTRIAL

For industrial wire rolling, Eurolls has developed the C microcassettes and D modular cassettes, available with steel or carbide rolls to meet specific production requirements.

To maximize flexibility, we also offer dedicated cassettes for high-carbon applications, equipped with carbide rolls designed to withstand high mechanical stress and elevated temperatures. All Eurolls cassette rolls can be PVD-coated in-house using advanced treatment systems, increasing durability by 30%, boosting productivity, and reducing costs.

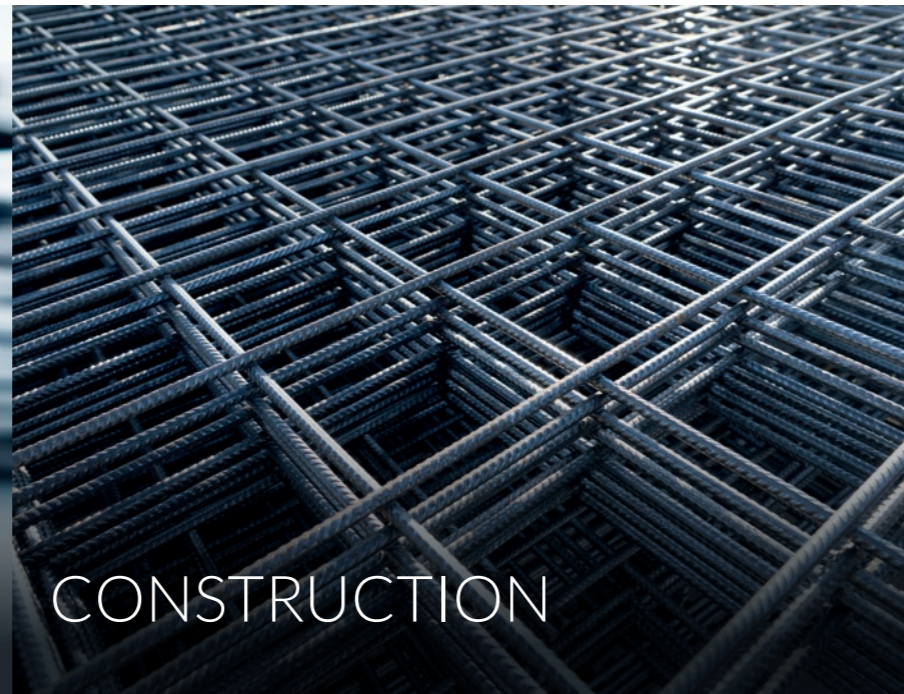

CONSTRUCTION

For cold rolling of construction wire, Eurolls offers the CA and CB cassettes, engineered to withstand high production stress while remaining easy to operate and maintain.

These cassettes are ideal for processing smooth or ribbed wire, on single- or multi-pass machines, replacing traditional dies. Rolls with PVD coatings deliver up to 130% longer service life, ensuring higher productivity and lower operational costs.

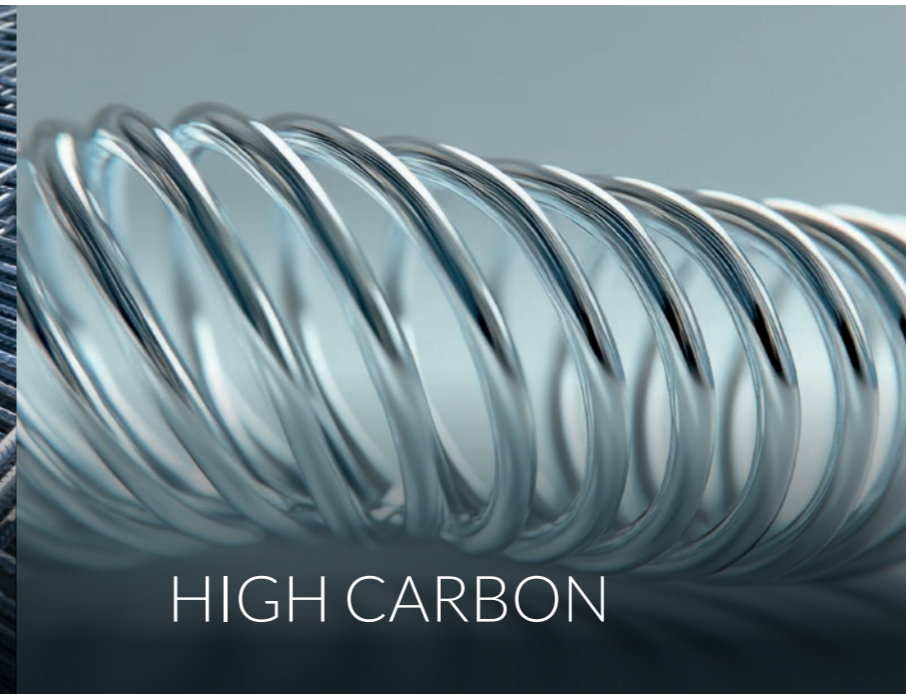

HIGH CARBON

Optimized Eurolls cassettes for high-carbon wire rolling.

For high-carbon wire rolling, Eurolls has adapted its proven construction and industrial cassettes to meet the extreme performance demands of these applications. This optimization is the result of deep technical expertise and extensive field testing.



SPECIAL APPLICATIONS

Customization is a core focus of our R&D department.

We design tailor-made cassettes for unique production requirements, ensuring reliability and ease of use even in non-standard operating conditions. Square, shaped, and flat wires are just some examples of the output achievable with these customized cassettes.

INNOVATION

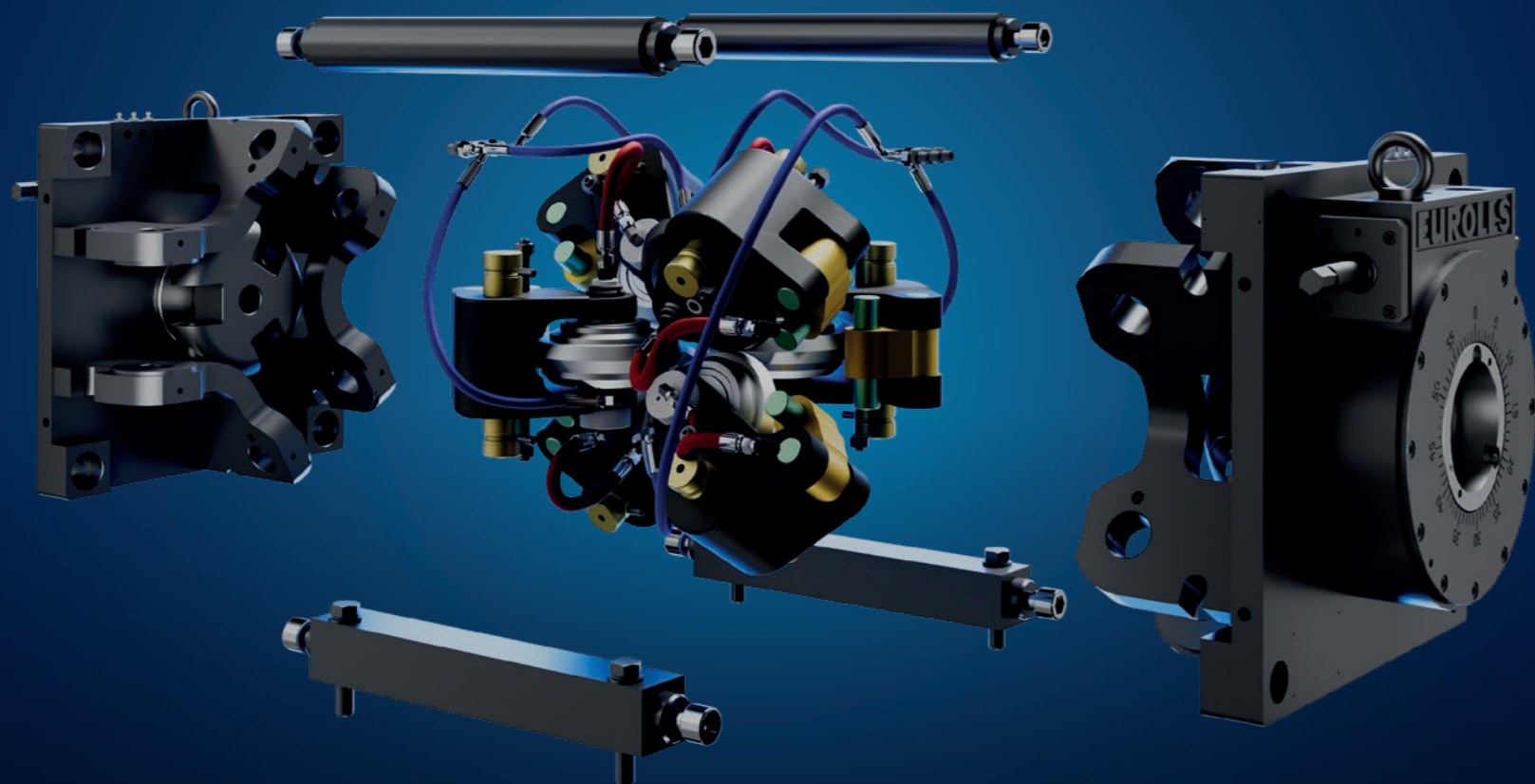

BLUE SKY BOX



In a world increasingly focused on environmental responsibility, where sustainability is a key element across all production sectors, Eurolls has patented the Blue Sky Box system, compatible with all drawing machines currently on the market.*

The system includes three accessories that can be integrated into Eurolls cassettes:

- Minimalub: a minimal air-oil lubrication system with separate circuits, ensuring constant lubrication of both the wire and the roll holder bearings;
- Protective cover: a polycarbonate shield designed to contain residual processing particles;
- Exhaust system setup: ready for integration with suction systems based on the specific needs of the wire drawing machine.

The BSB system offers several significant advantages:

- Elimination of powdered soap for wire lubrication
- Elimination of grease for bearing lubrication
- Reduced maintenance and operating costs
- Improved cleanliness and health of the working environment

*Subject to verification by Eurolls.

BLUE SKY BOX

PROTECTIVE COVER

A polycarbonate cover designed to contain residual particles generated during processing.



VACUUM SYSTEM

Integrated based on the specific requirements of the wire drawing machine.



MINIMALUB

Minimal air-oil lubrication system with separate circuits, ensuring continuous lubrication of the wire and roll holder bearings.



MOTORIZED SYSTEM



To meet the demands of intensive production, Eurolls has developed a motorized adjustment system for the final-pass cassettes in the production line. These cassettes work in combination with a laser gauge at the wire exit point, which maintains the wire diameter constant. The system automatically adjusts roll pressure and wire diameter, resulting in a minimal deviation compared to the target.

This laser gauge can also be integrated with a system that measures rib height, width, and pitch, ensuring compliance with internal quality standards.

ADVANTAGES

- Drastic reduction of weight-related scrap
- Precise tracking of production data (by hour, shift, weight produced, etc.)
- Full monitoring of process parameters (temperature, speed, vibration, water flow, etc.)
- Compliance with company-imposed standards
- Fewer machine stops, reduced scrap, and fewer errors

SMART 4.0

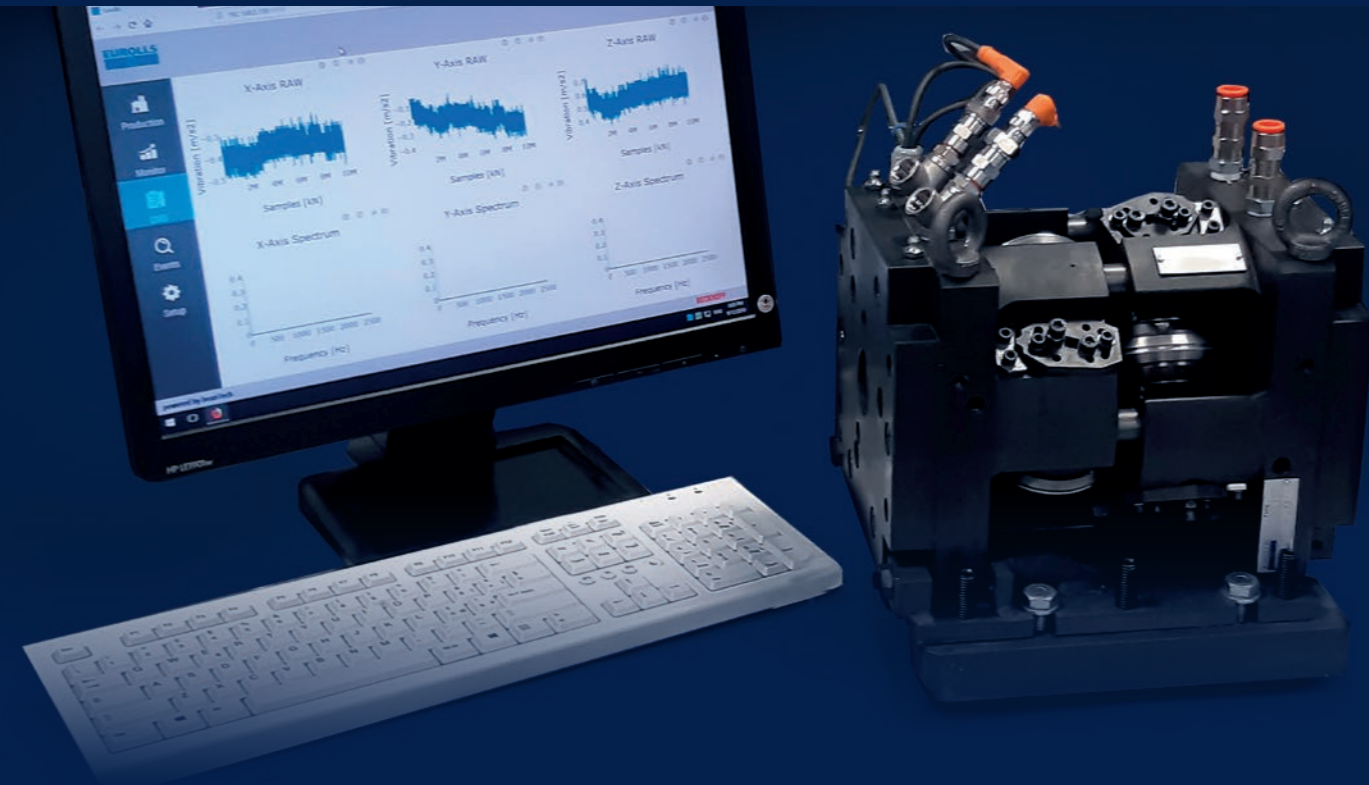

For those looking to enter the world of automated regulation without overhauling their production line, Eurolls has developed sensor packages that detect key production parameters and help prevent anomalies that could slow down the process.

These packages enable remote monitoring of:

- TEMPERATURE
- PRODUCTIVITY
- PREVENTIVE MAINTENANCE

Choose Eurolls to make your production smarter!

INDUSTRIAL WIRE

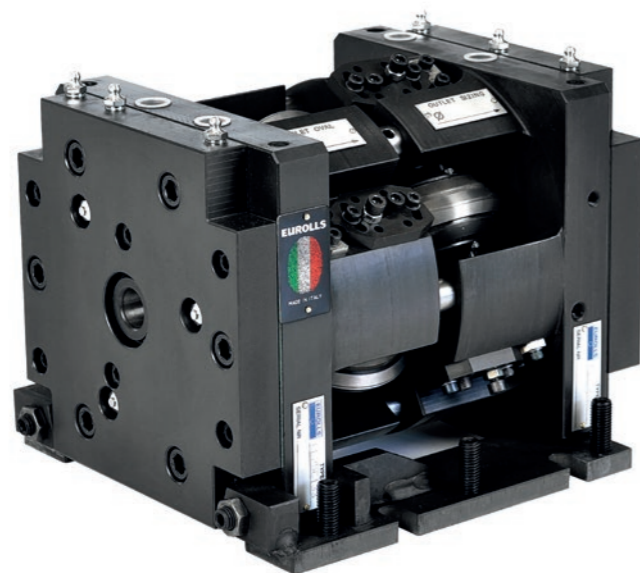

Eurolls offers microcassettes and modular cassettes for industrial wire rolling, available with steel or carbide rolls and optional PVD coating. All rolls are supplied pre-assembled on roll holders.

C Microcassettes – Compact and precise, ensuring exceptional uniformity and surface finish, replacing dies in multi-pass lines with tight tolerances.

D Modular Cassettes – Multiple modules offset by 90° are ideal for significant wire reductions, distributed across the various sections of the cassette, thus reducing deformation.

ADVANTAGES / FEATURES

- Reduced machine downtime
- Increased productivity
- Lower pulling force with reduced risk of wire breakage
- Longer roll lifespan
- Lower lubricant (soap) consumption

INDUSTRIAL WIRE

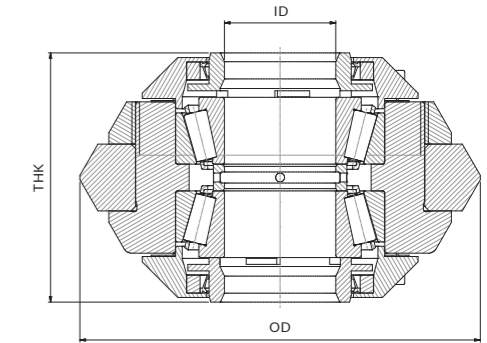

CASSETTE	WIRE TYPE	ROLLED MATERIAL	NUMBER OF ROLLS	Ø MAX INLET (mm)	Ø MIN OUTLET (mm)	ROLL DIMENSIONS (mm) OD/THK/ID
CL20D20 From 2 to 6 modules	Flux cored Smooth	Low carbon Stainless steel Titanium	2 per module	5	0,8	75/40/20
CL30D20 From 2 to 6 modules	Flux cored Smooth	Low carbon Stainless steel Titanium Brass	2 per module	10	1,4	110/60/30
CL20R20 From 2 to 6 modules	Flux cored Smooth	Low carbon Stainless steel Titanium	2 per module	2	0,8	55/45/20
CL25C133	Smooth	Low carbon Medium carbon Stainless steel Aluminium Nickel alloys HSS	3+3	5,5	0,8	90/65/25
CL20C133	Smooth	Low carbon Medium carbon Stainless steel Aluminium Nickel alloys HSS	3+3	4	0,8	75/51/20
CL30C133	Smooth	Low carbon Medium carbon Stainless steel Aluminium Nickel alloys HSS	3+3	10	1,2	110/65/30

CONSTRUCTION WIRE

The CA and CB models are specifically designed for the cold rolling of construction wire, featuring a reinforced structure engineered to withstand maximum production stress. They combine ease of use, quick maintenance, and high precision to deliver higher productivity through efficient operation, reduced downtime with faster maintenance and lower operating costs by minimizing machine time. The carbide rolls are PVD-coated.

ADVANTAGES / FEATURES

- Higher working speed
- Longer roll lifespan
- Reduced maintenance
- Increased productivity

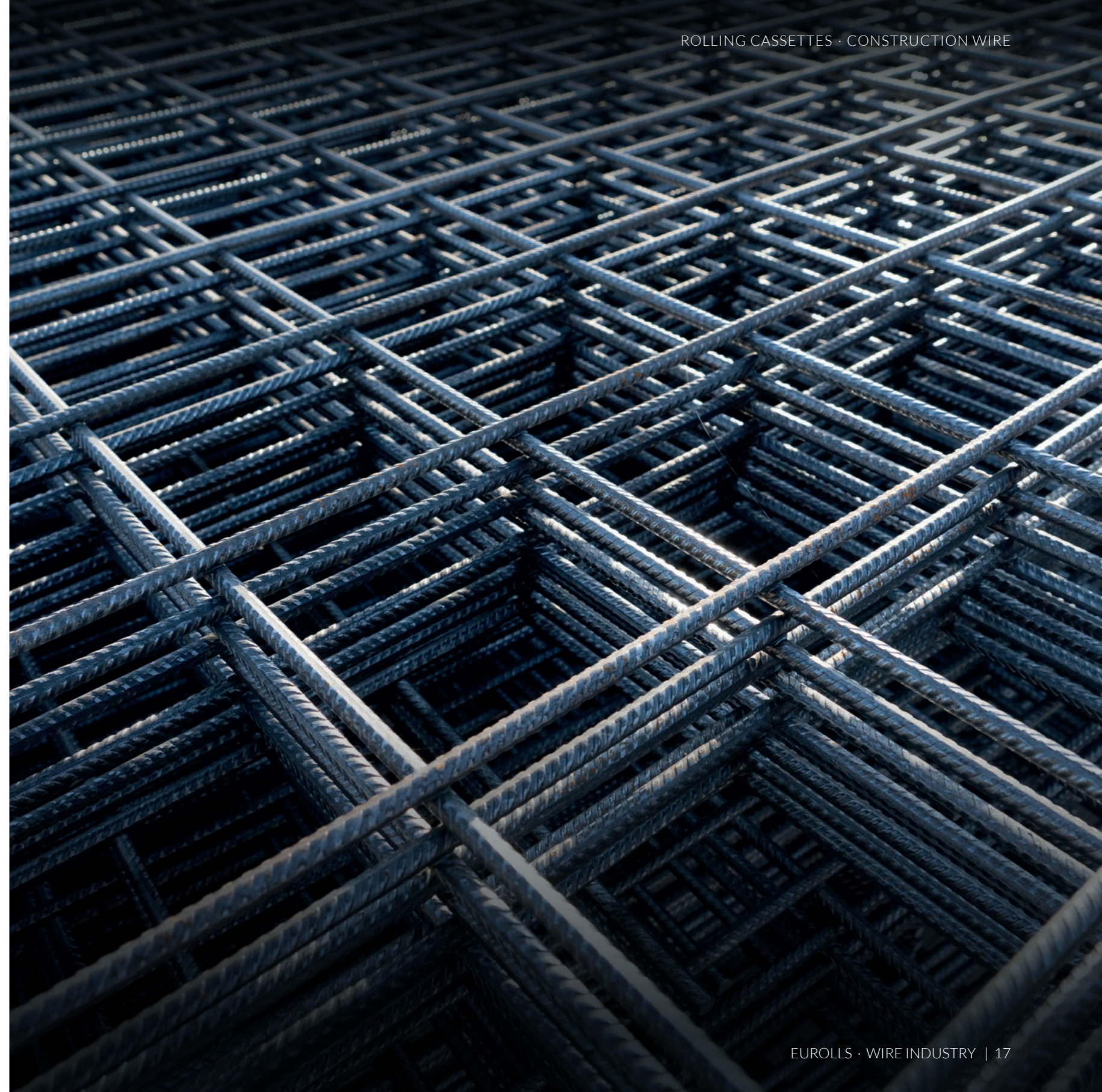

CONSTRUCTION WIRE

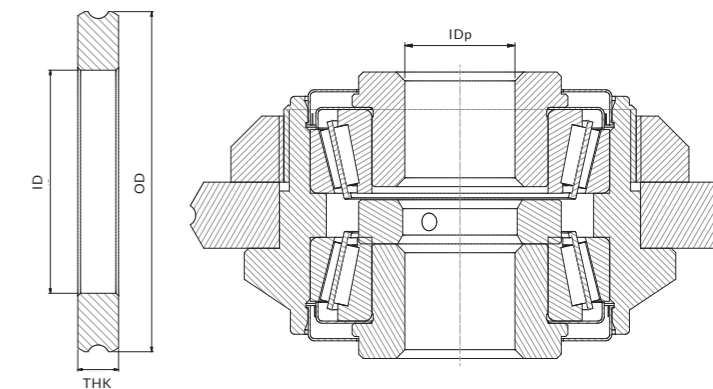

CASSETTE	WIRE TYPE	ROLLED MATERIAL	NUMBER OF ROLLS	Ø MAX INLET (mm)	Ø MIN OUTLET (mm)	ROLL DIMENSIONS (mm) OD/THK/ID	PIN DIMENSION (mm) IDp
CL25CB33	Ribbed Smooth	Low carbon Medium carbon	3+3	14	3	125/82/15 125/82/20	25
CL30CA33	Ribbed Smooth	Low carbon Medium carbon	3+3	18	4	140/90/15 140/90/20 150/90/15 150/90/20	30
CL25CB20	Ribbed Smooth	Low carbon Medium carbon	2	14	3	125/82/15 125/82/20	25
CL25CB22	Ribbed Smooth	Low carbon Medium carbon	2+2	14	3	125/82/15 125/82/20	25

SPARE PARTS

Thanks to its fully in-house production cycle, Eurolls ensures short lead times for spare rolls and roll holders for every cassette model. Whether for calibrating, forming, reducing, or profiling, each roll can be customized with the required surface treatment to extend service life and optimize production efficiency.

HIGH CARBON

A dedicated line for processing high-carbon material, enhancing the features of traditional cassettes to meet the specific demands of an application that requires special attention and guaranteed performance.

ADVANTAGES / FEATURES

- Maintains lower and constant wire temperature
- Increases production speed
- Produces a product with greater tensile strength, uniformity, ductility, and superior quality

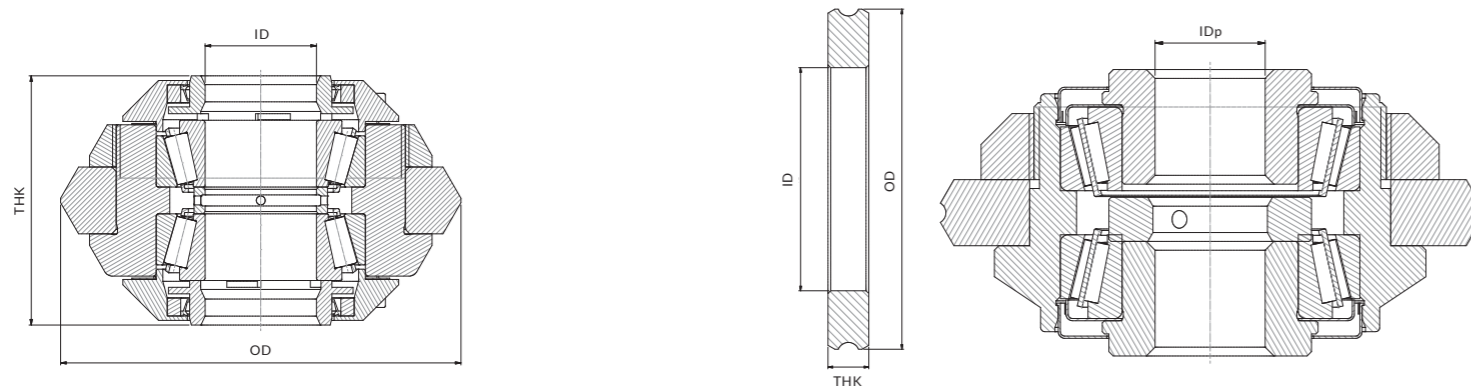

CASSETTE	WIRE TYPE	NUMBER OF ROLLS	Ø MAX INLET (mm)	Ø MIN OUTLET (mm)	ROLL DIMENSIONS (mm) OD/THK/ID	PIN DIMENSION (mm) IDp
CL40F133*	Smooth PC wire	3+3	14	1,5	140/65/40	
CL40G120* From 2 to 5 modules	Smooth PC wire	2 per module	12	1	140/65/40	
CL30CA33	Indented PC wire	3+3	12	3	150/90/15 150/90/20	30
CL45CI520	Indented PC wire	2 synchronized	18	3	150/110/20	45
CL30CA22	Smooth PC wire Indented PC wire	2+2	10	3	150/90/15 150/90/20	30
CC8	Strand PC wire	8	18	2	91/25/58	

*Supplied with preassembled rolls

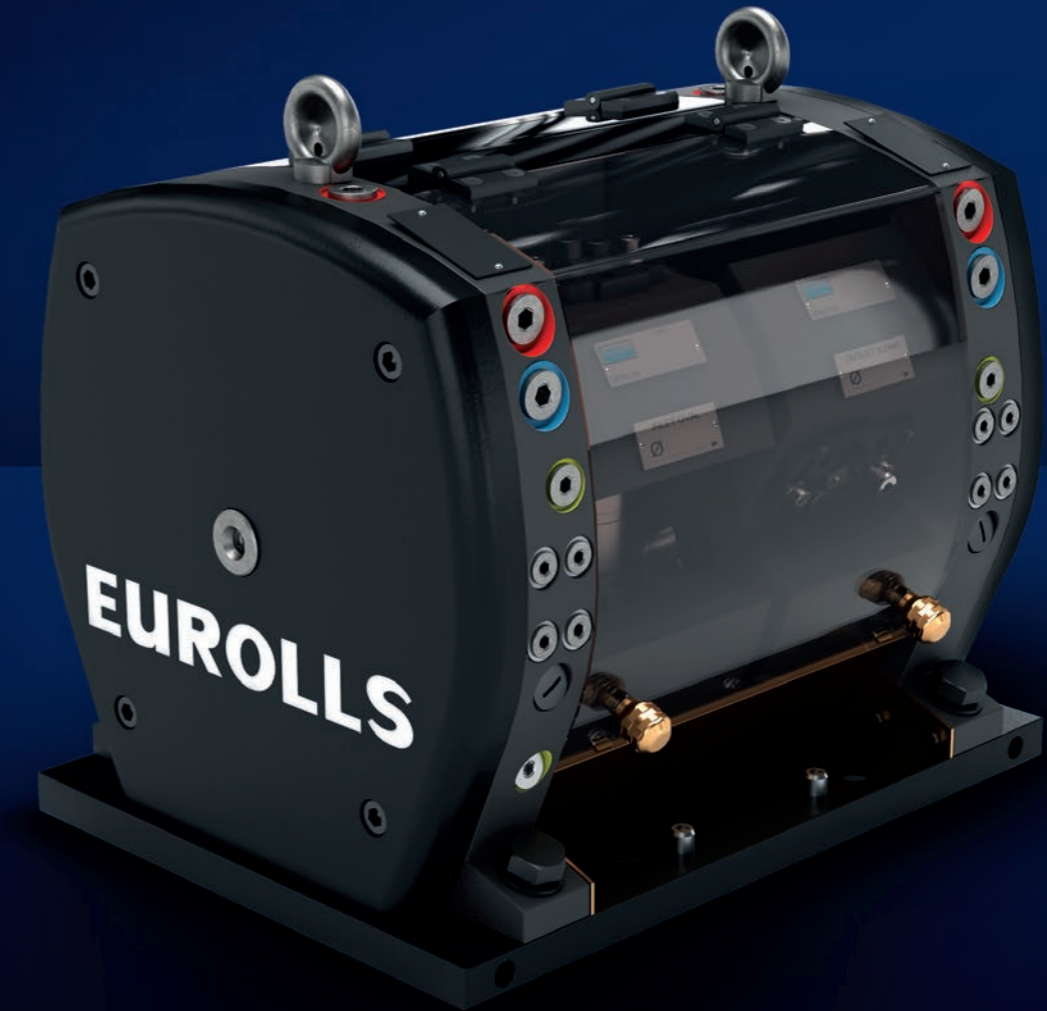

SPECIAL APPLICATIONS

Our R&D department designs suitable models to meet special requirements: cables, flat wire, special profiles (square, shaped, etc.). Each cassette is built with specific configurations to ensure high dimensional precision, process stability, and reliability even under extreme conditions.

ADVANTAGES / FEATURES

- Versatile use across multiple profiles
- Customizable configurations
- High precision and durability

CASSETTE	WIRE TYPE	ROLLED MATERIAL	EXAMPLES OF PROFILE TYPES PRODUCED
CL20RM3	Twisted Pitch from 20 to 50 mm	Low carbon	Square Hexagonal
CR170/4	Twisted Pitch from 60 to 150 mm	Low carbon Medium carbon	Square
CL25TQ40	Shaped	Low carbon Medium carbon Stainless steel	Square Rectangle
CL25CB33	Shaped	Low carbon	Triangle
CL25CB22	Shaped	Low carbon	Flat Oval
CL20D20	Shaped	Low carbon Medium carbon Stainless steel Titanium	Tear drop Flat Oval



ROLLS FOR SPECIAL APPLICATIONS

From the initial roughing stages to the final straightening, Eurolls designs and manufactures a complete range of rolls to meet the varied needs of wire and metal semi-finished product processing. Our rolls are built for maximum reliability, durability, and precision.

Each roll is made from premium materials — including special steels and hard metals — and engineered to optimize every phase of the production process.

In addition to cold processing, our range includes steel rolls for hot rolling copper, as well as hard metal or steel rolls for aluminum.

The result is a wide range that includes rolls for:

- **DESCALING, STRESS RELIEVING, AND ROUGHING:** specialized rolls for wire rod preparation, improving its mechanical properties.
- **FORMING AND ROLLING:** dedicated solutions for producing flat wires, fine wires, and components made from special alloys for technical and electrical applications.
- **PULLING AND HANDLING:** motorized rolls designed to ensure proper wire feed in critical zones.
- **HOT PROCESSING:** steel or carbide rolls for rolling copper, aluminium, and alloy steels.
- **FINAL STRAIGHTENING:** high-performance rolls for straightening machines used on structural profiles such as V, T, and U shapes, hot-rolled.

Every solution reflects our deep application expertise and is produced entirely in-house under certified processes — ensuring complete control and maximum customization.

ACCESSORIES FOR ROLLING CASSETTES

To maximize efficiency and reduce downtime, Eurolls offers a dedicated range of tools for the maintenance, assembly, and inspection of rolling cassettes, including maintenance benches, bearing preload tools, die disassembly benches, centering optics for microcassettes and roll alignment optics for microcassettes. All accessories are designed to ensure precision and safety at every stage of the process.



Roll alignment optics for microcassettes



ROLL HOLDER UNLOCKING NUT DEVICE
Usable with CA and CB cassettes, they allow quick removal of the roll-holder nut, making roll replacement easy and preventing damage.



CUSTOMER SERVICE

Eurolls supports its customers not only with cutting-edge technological solutions, but also with a full package of services designed to ensure operational continuity, maximum efficiency, and dedicated technical training.

Thanks to a specialized team and a long-term collaborative approach, we are able to offer:

- INSTALLATION AND INITIAL TRAINING**
 Complete support during design and commissioning phases, with technical training on proper equipment use and performance optimization.
- ONGOING TRAINING**
 Technical training programs available on demand or via subscription, ideal for keeping personnel up to date and transferring strategic know-how to those using our products daily.
- ON-SITE MANAGEMENT**
 Option for dedicated Eurolls technical staff to provide continuous on-site support for operational line management.
- EXTRAORDINARY MAINTENANCE AND REGRINDING**
 High-precision restoration and mechanical work carried out at our facilities, using specialized equipment and certified quality standards.

Each service begins with a thorough understanding of our customers' production needs and is transformed into practical, results-driven solutions — with the aim of building lasting relationships founded on trust and measurable performance.





Eurolls, innovation that keeps you rolling!

Our ambition is to be the global reference in the production of rolls and accessories for the tube and wire industry. Built on decades of experience and technical expertise, we deliver the best solutions and continue to grow as a market leader in our field.

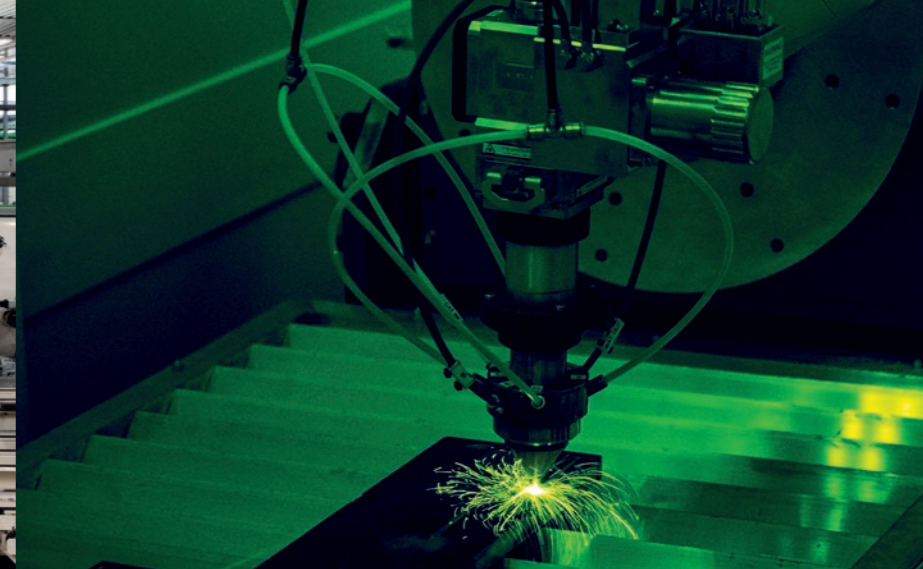

RESEARCH & DEVELOPMENT

Innovation at the core

The path to innovation starts with research. The synergy between Eurolls and academic institutions – including universities and research centers – has been a key factor in our success. These collaborations fuel the development of innovative, high-quality products, which is the result of advanced R&D processes grounded in scientific excellence.

CUSTOMIZATION

Tailor-made solutions

We turn your vision into reality: we provide customized solutions with the perfect blend of creativity, functionality, and innovation – all designed to meet your specific needs.

IN-HOUSE PRODUCTION CYCLE

Eurolls has fully internalized its production processes, including the creation of a dedicated Coating Division for special treatments and coatings on all types of substrates. This enhancement allows us to expand our offering and tailor products to each customer's requirements. It has also led to important partnerships with internationally renowned research institutes, including the Italian National Institute for Nuclear Physics (INFN).

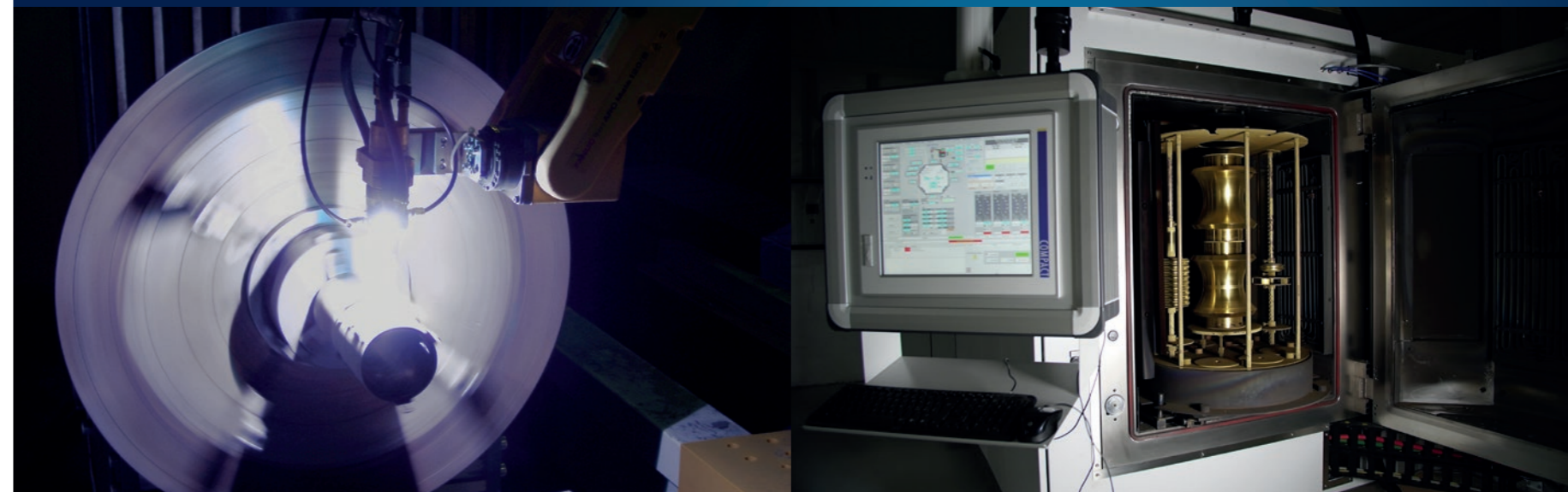

GLOBAL VISION

With 7 production plants in Italy, subsidiaries in Brazil, Mexico, China, and the USA, and a global network of agents and distributors, Eurolls delivers complete and efficient service worldwide.

Our reliability and customer dedication have earned us the trust of over 2,000 clients worldwide, with a production capacity exceeding 100,000 rolls per year.



PLANTS

EUROLLS (Italy)

HQ and steel products
Via Degli Ortolani, 54
33040 Attimis UD
Phone: +39 0432 796511

T.C. Products
Via Arturo Malignani, 14
33040 Attimis UD

Steel Products
Via Divisione Julia, 22
33029 Villa Santina UD

Special Products
Via Divisione Julia, 35
33029 Villa Santina UD

Finishing and Grinding Processes
Via Prato 28A
33010 Resia UD

BRANCHES

EUROLLS CARBIDE

Carbides Sintering Plant
Viale Industria, 41
20010 Boffalora Sopra Ticino MI

EUROLLS INDUSTRIAL

Wire Machines Production Plant
Via Str. di Salt, 66
33047 Remanzacco UD

QSTAHL

Special Products
Via Divisione Julia, 33
33029 Villa Santina UD

EUROLLS DO BRASIL

Steel and tungsten carbide rolls production plant
R. Flôr de Noiva, 980 – Una
Itaquaquecetuba – SP 08597-630 – Brazil
Phone: +55 11 4645 3626

EUROLLS DE MÉXICO

Steel and tungsten carbide rolls production plant
Parque Industrial, Unidad Nacional 2020
Industrial Unidad Nacional I
66360 Cdad. Santa Catarina, N.L. – Mexico
Phone: +52 81 833 608 40

EUROLLS USA

Sales office
2 Stoney Hill Lane
Mount Laurel, NJ 08054
Phone: +1 609 410 0731

EUROLLS SHANGHAI

Sales office and production plant
N.1070 Chen Xiang Lu
Nanxiang, Jia Ding, Shanghai - China, 201802
Phone: +86 021 691 778 04

